

Baseline Testing Provides Opportunities For Continuous Improvement

> Examining the past for future advancements

BY ROBERT VAUGHAN, WALLY BRATEK
AND MICHAEL HAHN

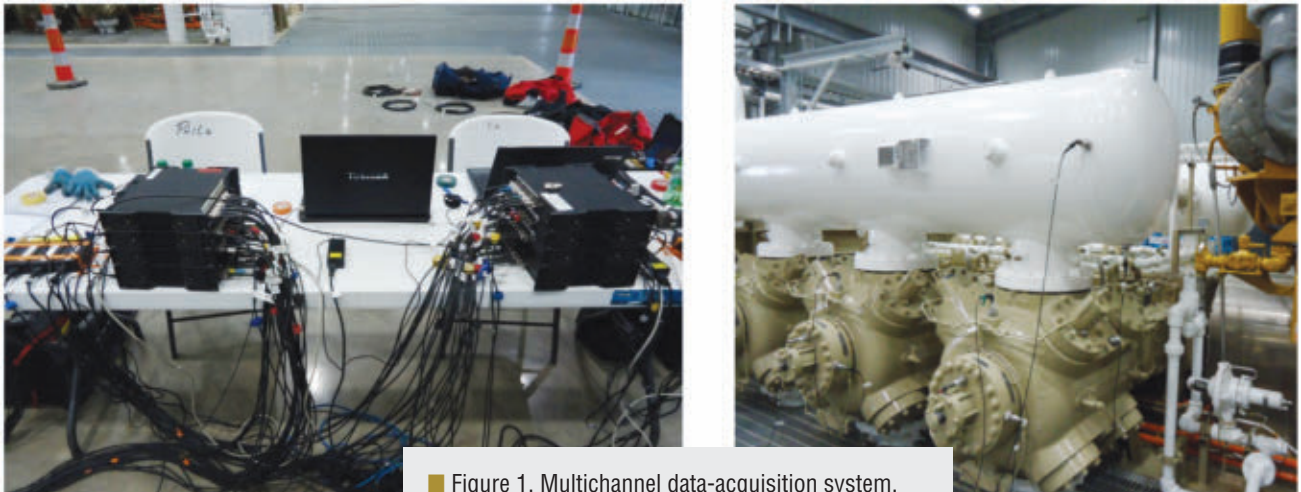

■ Figure 1. Multichannel data-acquisition system.

Editor's Note: *This paper was presented at the Gas Machinery Research Council meeting in Nashville, Tennessee, Oct. 5-8, 2014.*

Continuous improvement is an important philosophy at Shell. For the rotating engineering team, this goal is accomplished by looking at each new facility and finding ways to improve the design, construction and commissioning process for the rotating equipment, balancing reliability and integrity objectives with impacts on capital and operating costs, practical design and operations.

Shell Canada has commissioned a 200 MMscfd (5.71×10^6 Nm³/d) gas plant located in northeastern British Columbia, Canada. The Saturn 1 project included the design, con-

struction and commissioning of five, electric-drive 6500 hp (4847 kW) KBZ/6 compressor packages. This is the third large-scale facility installed in the region and it includes a number of improvements from the first one. Later, improvements were applied to the Sundance Compressor/Dehy Station, which has 1680 hp (1253 kW) JGK/4 and 840 hp (626 kW) JGK/2 compressors.

By examining the results of the baseline vibration testing and past compressor installations, Shell has identified a number of reliability and integrity improvement opportunities for reciprocating compressor packages. Beta Machinery Analysis (BETA) was involved as part of the design team for these facilities, conducted the onsite baseline testing, and supported Shell with the improvement initiative.

Baseline vibration testing approach

Continuous improvement requires accurate data to make informed decisions. The best way to obtain this is through a baseline testing and inspec-

tion program. This allows the owner to compare the actual field results with the intended design. Three issues to address when developing the testing plan are determining the method of data collection, defining the required scope, and comparing field results to the design model.

Vibration analyzers

The testing system must collect a large amount of data to identify the worst-case problems for machines operating across different conditions and speeds. Vibration measurements are needed at many locations in the piping system and should be collected at various conditions, load steps, and across the entire speed range. For these reasons, a multichannel analyzer, with the capability to simultaneously measure 50-plus channels, has many advantages.

Utilizing a multichannel analyzer for baseline testing, as shown in Figure 1, minimizes the need to conduct multiple tests and speed sweeps, thereby reducing the stress on the

Robert Vaughan, PEng, PMP, is a staff rotating equipment engineer at Shell Global Solutions. **Wally Bratek**, MSc, PEng, is a principal engineer at Beta Machinery Analysis. **Michael Hahn**, PEng, is a project manager at Beta Machinery Analysis.



■ Figure 2. Torsional strain gauge instrumentation.

compressor and saving considerable measurement time. After the initial transducer setup is complete, the compressor can be ramped through the speed range while collecting each of the vibration test points at once. Then, load steps can be changed, and the test is repeated.

This kind of comprehensive test would be very difficult with only a two- or four-channel analyzer, since the few transducers would have to be manually moved between tests, and many compressor speed sweeps would be required. Also, with fewer channels and multiple speed sweeps, there is a loss of consistency in the data since pressures may change between speed sweeps and the vibration phase relationship between vibration test points is lost.

While a two- or four-channel analyzer is sufficient for troubleshooting work where the focus is on a specific vibration problem area, a multichannel analyzer is required for comprehensive baseline vibration testing.

Scope of vibration testing

Often, owners and operators focus on the equipment on the skid and forget to measure important risk areas off-skid, such as header piping. For a large unit, on-site testing time ranges between one and two days, depending on the facility. After agreeing on a

vibration screening guideline, the following scope is suggested for a comprehensive baseline vibration test:

- Confirm that pulsations match expected values.
- Check vibration and resonance in main piping, skid and frame — across the run speed for key operating conditions and load steps.
- Check on-skid small-bore and pressure safety valves (PSV) for resonance.
- Check off-skid piping and small-bore attachments.
- Check that torsional vibration and torsional natural frequencies match the design requirements (Figure 2).
- Inspect pipe clamp installation, shimming, supports, etc.
- Check the foundation to confirm if skid or machinery has high vibration, and confirm the pile attachment to the main skid, especially

continued on page 52

Synthosol

QUALITY LUBRICANTS YOU CAN DEPEND ON.

Stocking locations in the U.S. & Canada

SERVICES
Customized Lubricant Application Selection
Oil Analysis • Lab and Problem Application Support
New Product Development

PRODUCTS
Semi Synthetics • Synthetic Polyalkylene Glycols (PAG's)
Synthetic Polyol Esters (POE's) • Synthetic Diesters
Synthetic Polyalphaolefin (PAO's)

866.366.5699 • Fax: 281.367.5685 • Synthosol.com
mpe@mastersprocess.com



■ Figure 3. Inspecting piles attached to skid with slip rings for Saturn 1, 6500 hp (4849 kW) KBZ/6 compressor package.

Pipe Size (in. [mm])	Angular Gap Tolerance for 300 lb ANSI Class Flanges (in. [mm])	
	ASME B31.3	API 686
2 (50.8)	0.019 (0.4826)	0.01 (0.254)
4 (101.6)	0.032 (0.8128)	0.011 (0.02794)
6 (152.4)	0.044 (1.1176)	0.013 (0.03302)
10 (254)	0.066 (1.6764)	0.018 (0.04572)
16 (406.4)	0.096 (2.4384)	0.026 (0.06604)

■ Table 1. Angular Gap Tolerance for ASME B31.3 vs. API 686

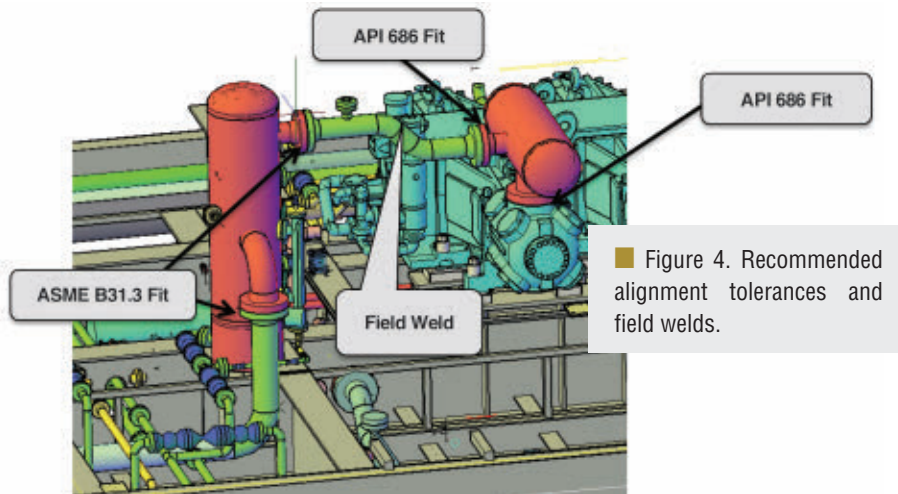

■ Figure 4. Recommended alignment tolerances and field welds.



■ Figure 5. Examples of pipe misalignment resulting in vibration issues.

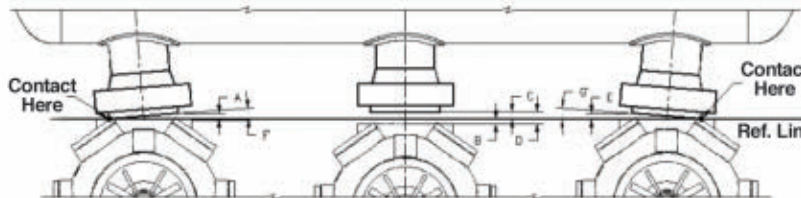

- at interior pile locations (Figure 3).
- Spot-check fit-up tolerances (based on testing results).
- Evaluate interaction between units (if multiple units connected to the same header).
- Check performance results.

Closing the loop: comparing field results to the design model

Before comparing the design analysis results to the actual field data, check if all of the design report recommendations have been implemented. Note that the field conditions may not match the data in the design report since worst-case conditions may have been used for the design. In these cases, results from the design report can be scaled to the field conditions, or the design models may have to be rerun to better match field conditions.

Piping tolerances, fit-up, and field connections

Field testing has verified that high-frequency vibrations are amplified in locations with excessive pipe strain or poor piping installation and fit-up [1]. Baseline vibration tests can identify locations where pipe strain is suspected. In severe cases, field modifications may be required to improve the flange or piping alignment. Improved design, shop testing and field connections will avoid these problems.

Alignment standards contained in ASME B31.3 are often insufficient for key areas of the compressor package, especially those between the scrubber and suction bottles [2]. To solve this problem, the authors recommend using API as design specification for these locations [3]. Table 1 shows a tolerance comparison between the ASME B31.3 and API 686 standards.

To avoid misalignment after transportation and lifting, the authors recommend leaving some welds for the field and to make preparations in the shop to achieve this (Figure 4). Shell's experience confirms that piping field welds at key locations will solve the fit-up challenge. Since other field connections are required at site, there is no significant impact by

Test Point	Speed Range											
	600 to 625	625 to 650	650 to 675	675 to 700	700 to 725	725 to 750	750 to 775	775 to 800	800 to 825	825 to 850	850 to 890	890 to 900
Unit 2												
2S18												
2S21												
2S21 Top Valve												

■ Table 2. Speeds to avoid chart (to prevent resonance).

field welding and hydro-testing a few additional piping spools.

It can be particularly challenging to achieve optimal alignment and fit-up of multicylinder pulsation bottles. If the fit between the bottle and the cylinders is poor, the stressed state of the bottle can result in excessive high-frequency vibration and fatigue failures. For this reason, the fit of the bottles onto the cylinders should be measured and documented (Figure 5). Also, post-weld heat treating is recommended on all pulsation bottles, to relieve the residual static stress state and thereby increase the capability of the bottle to better withstand vibratory stress.

Managing mechanical resonance

For most high-speed compressors, there is a strong possibility that one or more areas may be resonant. For high-speed compressors operated across a wide speed range, resonance is unavoidable. This means the design team must address the trade-off between mechanical resonance, operating speed range and installation costs.

The most common solution to address mechanical resonance is to modify the piping system and supports to shift the mechanical natural frequency (MNF) away from resonance. Typically this entails increasing the MNF by adding bracing, or in some cases detuning the system by reducing stiffness or adding mass. However, there are other alternatives to address a mechanical resonance problem that may result in less costly solutions.

If adequate baseline testing is completed to precisely measure mechanical natural frequencies, then it is possible to block out only a small speed range to avoid a mechanical resonance problem. An example of a speed block-out

report is shown in Table 2. Blocking out specific speeds can be considered when system modification costs re-

quired to operate at the whole speed range may not be justified.

continued on page 54



■ Figure 6. Grout box mount.

■ Figure 7. Steel block mount.

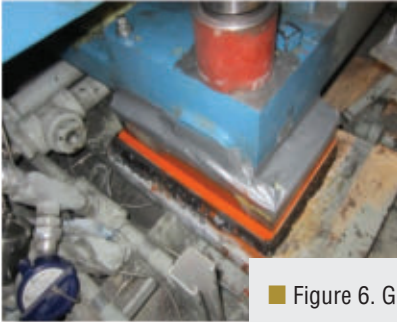

or utilizing a recycle valve. Therefore, from an overall cost and reliability standpoint, the blocking out of speed may be the best solution to address mechanical resonance problems.

An additional option to address a mechanical resonance vibration problem is to add damping to the system to reduce the resonant vibration amplitude to acceptable levels. A current GMRC research project provides information on damping options.

**Revision 1 And 2
Conventional Sight Glass Attachment**



**Revision 3
Studding Outlets With Sight Glass**

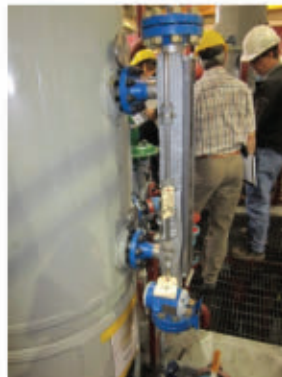

**Revision 4
Sight Glass Replaced With Ultrasonic Level Switches**

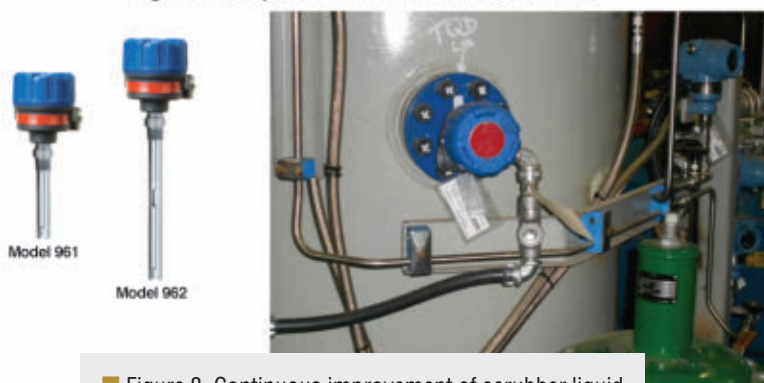

■ Figure 8. Continuous improvement of scrubber liquid level indication.

Compressor skid mounting

There are two main ways to attach the compressor frame and distance piece supports to the main skid; one uses grout, the other uses machined steel blocks.

Grouting compressors (frames and distance pieces supports) can be done quickly in a controlled shop environment, as shown in Figure 6. When using grout, key issues include selecting the right grout and sizing of the grout box to result in acceptable deflection. Grout manufacturers provide engineering manuals for how to complete the proper grout box calculations [4]. Determining the differential thermal expansion and sealing joints of the grout box are also important considerations.

While grouting small horsepower applications is likely sufficient, applying more weight or stronger forces can lead to cracking. It is important not to overstress the grout by over-tightening the bolts.

If grout is used, selecting the right

The speed block-out solution may initially create concerns for the operating staff; however, methods other than speed are available to fine-tune

capacity control if certain speeds are blocked. These include coordination between other units, cylinder loading, throttling with a suction control valve,

color (grade) grout is important and should be considered in the grout box area calculation. Furthermore, if grouting is done at site, controlling environmental heat and curing times can be difficult.

An alternative to grout is the use of steel on steel supports, as shown in Figure 7. In this method, steel blocks are first welded down and then machined. It is important not to weld down pre-machined steel blocks, since it defeats the purpose of achieving a flat pane for all of the compressor feet. Compared to grout, steel supports are very stiff since steel has a much higher modulus of elasticity than grout. Additionally, steel blocks are better to transfer compressor loads effectively into piles (as design is intended), and they are more reliable for larger horsepower machines.

Small-bore connections — scrubber-level gauge

Failures of small-bore piping and attachments are a significant reliability and safety concern near reciprocating compressors [5]. Comprehensive

baseline testing can reduce the risk of small-bore piping failures by ensuring acceptable vibration. Further, information from the baseline testing can be used to improve the design of small-bore attachments for future projects.

Regarding the design and fabrication, end-user (owner or operator) involvement is important to address these vibration and integrity risks. This includes improved specifications, standards and inspections. To mitigate these risks, designers often have to remove, redesign, or realign small-bore connections. This includes reviewing designs to find the best approach for the scrubber attachments, including liquid-level controllers. The authors recommend shop inspection and testing in the field to avoid resonance problems. They also recommend avoiding threaded connections in vibration services.

An example of the continuous improvement process, Figure 8 shows the progression of the design of liquid-level measurements on suction scrubbers. The revision 1 and 2 design is

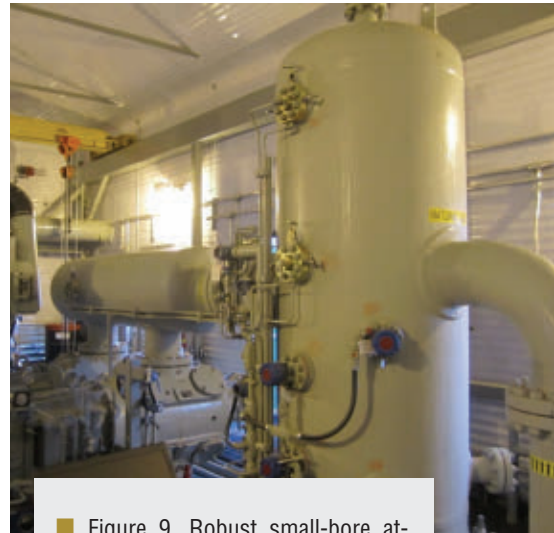

■ Figure 9. Robust small-bore attachment design at Sundance is the result of continuous improvement and effective end-user specification.

typical and can be a vibration problem, since the offset from the scrubber shell wall is relatively large, and the diameter of the pipe connections to the shell are relatively small. The design shown

continued on page 56

ReInventing Efficiency

Higher efficiency means dollars saved. The ACI team of Compression Experts developed new, radial poppet valve and capacity control technology to manage capacity, reduce fuel consumption, lower emissions and increase overall revenue. Call the ACI Compression Experts today for more information on the next generation valve technology.



Radial Valves

Radial Deactivator

Rotavator™

Single Deck Valves

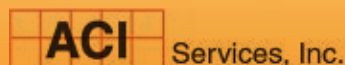

ACI Services, Inc. • Cambridge, Ohio • www.ACIServicesInc.com • (740) 435-0240



Field Vibration Measurements On Small-Bore Attachments Is 1.8 in./s (45.72 mm/s)

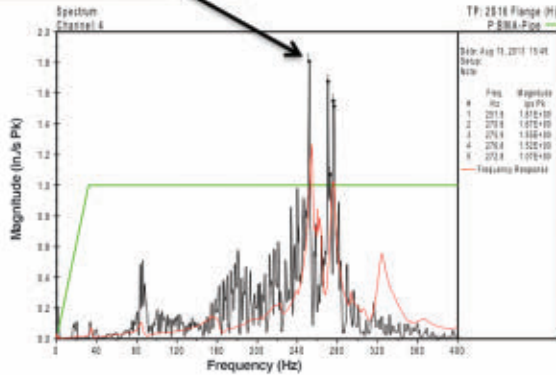
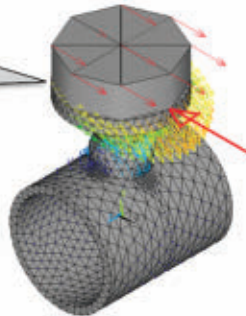

Figure 10. Field testing of small-bore attachments.

Finite Element Analysis Confirms That The Maximum Allowable Vibrations Are 2.1 in./s (53.34 mm/s) For This Specific Small-Bore Geometry, To Meet Allowable Stress Criteria. Therefore, The Field Vibration Measurement Of 1.8 in./s At 252 Hz Is Acceptable.



plitude, where technically the vibration is above a vibration guideline, however not at a vibration level that would be considered obviously unacceptable. In these cases, a finite element model can be utilized to define the relationship between measured vibration and dynamic stress at the connection, and ultimately determine if the vibration is acceptable. An example of this process is shown in Figure 10. In the small-bore connection shown, vibration was measured to be 1.8 in./s (45.72 mm/s), which is more than the agreed upon vibration guideline of 1 in./s (25.40 mm/s). However, for this specific case, a finite element analysis of the connection proved that this level of vibration is, in fact, acceptable.



Figure 11. Temporary cone-shaped startup strainer.

Small-bore connections — suction strainer differential pressure measurements

Temporary startup screens or strainers, as shown in Figure 11, are very common for the commissioning of reciprocating compressor packages. These cone-shaped screens keep debris and dirt out of the cylinder and path of the piston. However, the fine mesh of these screens can plug up quickly during commissioning of a new plant. If not kept clean, they can buckle and be pulled into the compressor. Therefore, it is important to monitor the differential pressure across the strainer.

For permanent differential pressure measurement, piping connection tees are often utilized on the suction piping and pulsation bottle, on either side

in revision 3 is more robust, utilizing larger-diameter studding outlets for connection to the scrubber shell, and a reduced offset distance. Revision 4 shows a design where the sight-glass component has been replaced with ultrasonic-level switches, resulting in the most reliable arrangement.

The small-bore piping design ac-

ording to the latest version of Shell's specification is shown in Figure 9. Note the low-profile robust design of the instrumentation connections, resulting in minimal risk of vibration and reliability problems.

During baseline vibration testing, many times the vibration of small-bore attachments is at marginal am-

Revision 1: Conventional Connection Tee



Revision 2: Monoflanges

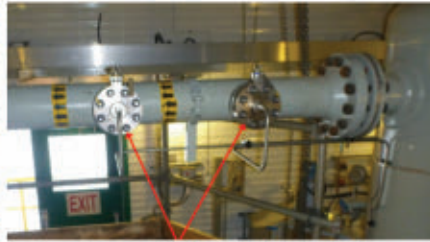

Revision 3: Using Tapped Flanges For A Temporary Attachment

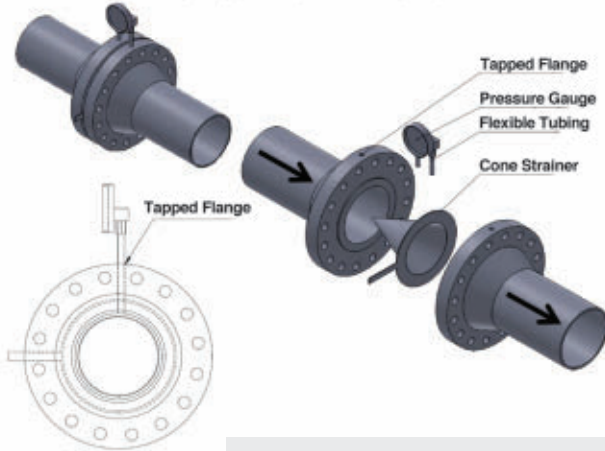

Figure 12. Continuous improvement for pressure differential measurements.

of the cone strainer. Individual isolation valves are also used, as shown in the typical arrangement in Figure 12, revision 1. Since this design is susceptible to small-bore vibration issues as previously described, an improved design was developed as shown in revision 2. Revision 2 utilizes monoflange valve assemblies to reduce the cantilevered length of the small-bore attachment and eliminate the need for threaded fittings in the gas process stream. While the revision 2 design is an improvement over conventional arrangements, it is still difficult to support the long lengths of tubing and is a rather expensive option.

After considering the fact that direct differential pressure is only monitored during compressor startup (CSU), it was decided that a robust permanent connection and isolation valves were not required. Therefore, the design as shown as revision 3 with drilled and tapped flanges will be used as the next iteration. Revision 3 will include flexible tubing to a temporary differential

continued on page 58

DETONATION PREVENTION!

Call today for more Information!



All trademarks, logos and symbols are exclusive objects to the right of their owners and are used for reference purpose only.

MOTORTECH Americas, LLC

Phone: 1-504-355-4212 | www.motortech.de | www.motortechamericas.com





■ Figure 13. Layout 1.



■ Figure 15. Plate-type outboard cylinder supports.



■ Figure 14. Layout 2.

pressure gauge, and have the benefits of being relatively inexpensive and removable. After the commissioning phase is complete, the tubing and gauge can be removed, and the tapped flange plugged. This eliminates the long-term, small-bore vibration risk.

Main piping and support design

There are many options and preferences for piping and support layouts. Baseline testing has resulted in improvements in key areas, leading to reduced vibration risks and providing for more robust designs.

The piping between the suction scrubbers and suction bottles, for example, is a high vibration risk since it is difficult to design supports with sufficient stiffness at the relatively high elevation of this piping. There are two common layouts as shown in Figures 13 and 14. Each of these has different advantages and disadvantages, and the best option will depend on the specific compressor application.

In layout 1, the suction piping leaving the scrubber is at a different elevation than the suction bottle. While the scrubber is more isolated from the compressor cylinder excitation, the likelihood of high spool vibration increases, and alignment and fabrication are more difficult since this will

likely require a field weld. In cases where the MNF of the piping spool can be designed to be above significant excitation frequencies, this design is preferred.

In layout 2, the suction piping leaving the scrubber is in-line with the suction bottle. With this design, the scrubber is not isolated from the compressor cylinder excitation to the extent that it is in layout 1, which may result in the increased risk of vibration problems for the scrubber and scrubber attachments. However, as a result of the increased stiffness and elimination of the 90° bend, vibration of the suction piping from compressor cylinder excitation will likely be avoided. This layout makes fabrication and alignment easy, and is preferred for higher-speed applications.

Another key aspect of high-speed compressor designs involves addressing the potential need for cylinder outboard (head-end) supports. Depending on the weight of the compressor cylinder and the speed of the compressor, certain cylinders may be mechanically resonant and require an outboard support, as shown in Figure 15. Addressing cylinder resonance problems in the field without adequate provisions designed into the system can be challenging and potentially very expensive, especially for compressors with pile foundations.

Therefore, during the mechanical analysis, the vibration specialist will identify the specific cylinders where there is a high risk of mechanical resonance. The best solution in these cases is to provide provisions for a cylinder support, even if the packager does not install the support. Provisions include ensuring that there is an adequate skid beam in the correct position under the head-end of the cylinder, designing piping and utilities to not block the area under the cylinder where a potential outboard cylinder support may be installed, and including piles under the skid beams located below the head-end of the cylinders. With these provisions, a cylinder outboard support can easily be installed in the field.

Baseline testing has also demonstrated that piping in the area of the pressure safety valve (PSV) or relief valve also requires special attention. This piping is subjected to both significant dynamic loading from pressure pulsations and significant differential thermal expansion loading since they are installed on the relatively hot discharge lines and vented to

continued on page 60

W E N O T O N L Y
K E E P O U R L I P S
sealed!

- Sealing Products for Reciprocating Compressors, Rotary Systems and Renewable Energies
- In house Material and Product Development utilising a Test Compressor and a Reciprocating Wear Test Rig
- In house Material Blending and Moulding of Proprietary STASSKOL Materials
- Protected After Market Strategy for all OEMs
- German Engineering



+49 (0) 3925 288 100

info@staskol.de

www.staskol.com



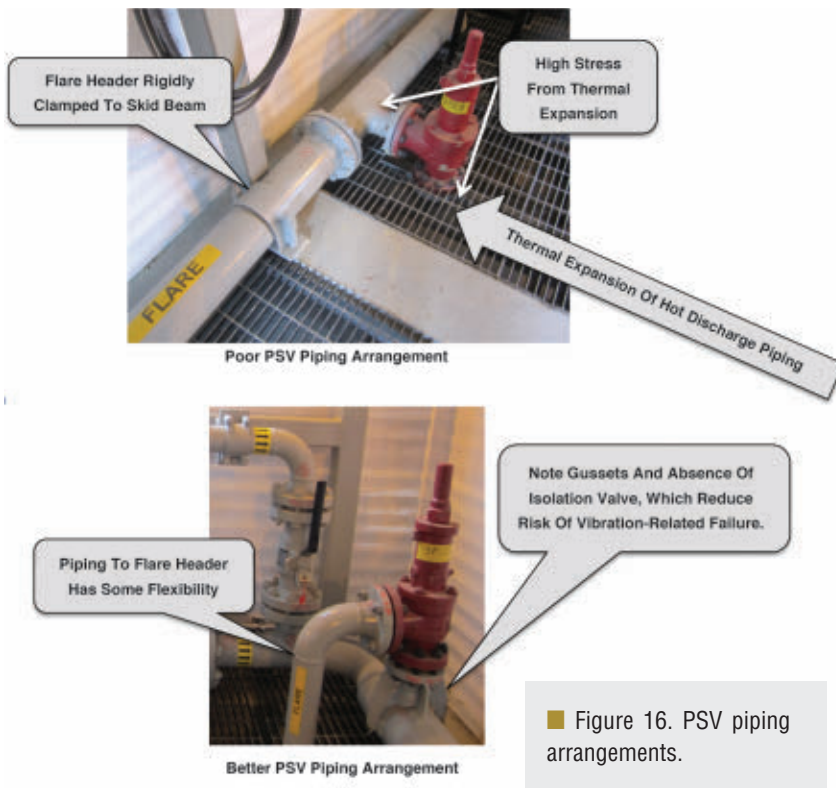

■ Figure 16. PSV piping arrangements.

a cool flare header. As the compressor warms up, the discharge piping grows longer as a result of thermal growth. If the PSV or the flare piping just downstream of the PSV is clamped down tightly, the PSV connection cannot grow with the discharge piping, and can become stressed. This has been shown to create pipe strain-related failures and excessive vibration. Therefore, the PSV piping design should consider both thermal and dynamic issues, as demonstrated in Figure 16.

Finally, baseline testing has shown that details such as the design and accurate modeling of pipe clamps (Figure 17) are important to achieve accurate simulation results, and provide the optimal pipe support solution, including the effects of both vibration and thermal expansion. Piping engineers concerned with only thermal flexibility often assume that pipe clamps are rigid anchors. This assumption is incorrect and results in added unnecessary flexibility, and can create vibration problems. Therefore, the clamps must be modeled to include friction when doing thermal flexibility analyses, and must not be over-tightened in the field such that the required flexibility is achieved. For information on accurate

stiffness and modeling techniques for pipe clamps, see the GMRC research project “Pipe Support Stiffness” [6].

Conclusions

This article has identified a number of lessons learned from Shell’s recent expansion project in Northeast British Columbia, Canada. This continuous improvement process requires an effective feedback loop that involves field testing and evaluation. By exam-



■ Figure 17. Pipe clamps for vibratory service.

ining past deficiencies and reliability issues, Shell and its team are able to modify its designs, specifications, inspections, commissioning, and project management activities. The authors hope that the ideas and opinions provided in this article will assist other owners to improve their installations, and stimulate further industry discussions about best practices. CT2

References

- [1] Maxwell, G., Howes, B., “Piping Misalignment And Vibration Related Fatigue Failures,” Gas Machinery Research Council (GMRC), 2013, http://www.betamachinery.com/assets/pdfs/Technical_Articles/Piping-Misalignment-Vibration-Related-Fatigue-Failures.pdf.
- [2] ASME B31.3, “Inspection, Examination, And Testing,” In “Process Piping, ASME Code For Pressure Piping, B31,” Chapter 6, Section 4-18.
- [4] Chockfast Engineering Manual, http://www2.sintemar.com/documentacion/catalogos/chockfast/prc_engineering_manual.pdf.
- [5] “Small Bore Connections (SBC) Assessment For All Machinery Types And Applications,” Beta, <http://www.betamachinery.com/services/small-bore-connections-sbc-assessment>.
- [6] “Pipe Support Stiffness, GMRC Project: Improving Piping System Reliability,” Beta, <http://www.betamachinery.com/wiki/pipe-support-stiffness/>.