

Recommended Approach to Control Vibration from Cylinder Gas Forces

Everett Houdyshell,
Maintenance Superintendent
Anadarko Petroleum Company
Author/Presenter

Bill Eckert, P.Eng., Ph.D.
Principal Engineer, Field
Services
Beta Machinery Analysis Ltd.
Author, Previous GMC
Author/Presenter

Wally Bratek, P.Eng.
Principal Engineer, Design Services
Beta Machinery Analysis Ltd.
Author/Presenter

Key words: vibration, gas forces, cylinder stretch, API 618, mechanical analysis

Abstract

Vibrations created by pressure pulsations are recognized as a common problem for reciprocating compressor facilities. However, there are other dynamic forces in reciprocating compressors that can, and do, cause serious vibration problems.

Foremost of these are gas forces from the pressure inside the compressor cylinder. When the gas forces become large, they cause motion of the compressor cylinder and create vibration problems in the attached piping and bottles. Vibration due to gas forces is one of the most common problems experienced by operators of compressor assets – especially for compressors with high rod loading.

Based on the authors' experience, problems result in piping failures, downtime and safety issues. This paper will explain the problem and highlight measures that should be taken. A case study at an Anadarko Petroleum Company facility is used to illustrate the gas force problem.

Currently, there are no industry standards that provide designers or fabricators a means of determining when dynamic cylinder gas forces will be a problem. The lack of standards creates reliability and operational challenges for the owner when purchasing or modifying a compressor package.

To overcome the lack of standards, it is recommended that operators include more stringent requirements for analyzing gas forces in the pulsation and vibration study when purchasing (or modifying) a reciprocating compressor package. The authors also suggest the next version of API Standard 618 include recommendations for analyzing vibrations due to gas forces.

Recommended Approach to Control Vibration from Cylinder Gas Forces

Introduction

For new or modified reciprocating compressor packages, it is common practice to have a pulsation and vibration study performed to avoid problems. API 618 defines the methodology and guidelines used for pulsation and vibration studies. The Standard does an excellent job of addressing pressure pulsations and methods to control forces from these pulsations. However, there are other forces in reciprocating compressors that can, and do, cause vibration problems and currently the guidelines and methodology are insufficient to address these other forces.

The dynamic gas forces from the pressure inside the compressor cylinder clearance volume is one such example. These dynamic gas forces cause motion of the compressor cylinder in the direction of piston motion at all orders of compressor speed. This motion is sometimes referred to as cylinder stretch or frame stretch. This cylinder motion can excite the attached piping and bottles resulting in excessive vibration, fatigue failures and, in extreme cases, a gas release and serious safety concerns [1].

Currently, there are no industry standards (including API 618, 5th edition) to provide designers or fabricators a means of determining when dynamic cylinder gas forces will be a problem. This means that, in some cases, the gas forces are considered insignificant and are ignored, resulting in costly field modifications. Without a proper standard, it is difficult to know if a vibration study has addressed these forces at all operating conditions, and at the different orders of run speed (harmonics).

This paper provides an explanation of the dynamic cylinder gas forces and their effects by means of a technical description and a recent case study at an Anadarko Petroleum Company (Anadarko) facility. The case study includes computer simulations and field measurements demonstrating the cylinder gas force problem. A description is given of a method to determine when a compressor installation may be susceptible to gas force vibration problems, based on evaluating the compressor operating parameters, as this approach fills a deficiency in API 618, 5th edition. Design practices for minimizing vibration from gas forces, and recommended field analysis techniques are discussed.

This paper is a collaborative effort between Anadarko and Beta Machinery Analysis (Beta).

1.0 Background on Gas Forces and Mechanical Analysis

1.1 Dynamic Forces

Reciprocating compressors generate high dynamic forces. These forces are due to the inertia of the piston and other reciprocating and rotating components, gas forces, and pressure pulsation induced forces in the piping and vessels. (Figure 1.1).

Dynamic forces are complex waveforms that can be represented by a series of vectors at multiples of the fundamental frequency (harmonics). A spectrum of typical forces is shown in Figure 1.2. For example, a compressor running at 1200 RPM (or 20 Hz), generates forces at the first order of run speed (referred as 1X, or 20 Hz). It also contains force amplitude at 2X (40 Hz), 3X (60 Hz), etc. The highest forces are usually at 1X and 2X, but the forces at the other harmonics need to be considered as well. Lower amplitude forces can result in high vibration if coincident with a mechanical natural frequency (MNF).

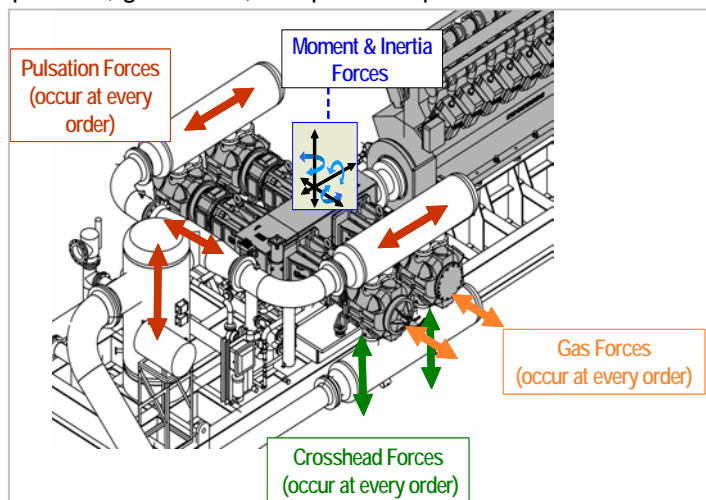

Figure 1.1: Dynamic forces affecting compressor

1.2 Cylinder Gas Loads or Cylinder Stretch

Cylinder stretch is a common term which refers to cylinder motion in the direction of piston motion. This motion is generated by the pressures inside the compressor cylinder clearance volume, and is often a significant source of dynamic excitation for the attached piping and vessels. During each stroke of the piston, gas is first compressed on the head end, and then on the crank end of the piston. The crank and head end pressures also act on the cylinder during each stroke. These pressures result in an alternating force acting on the compressor cylinder. This force causes the cylinder assembly to lengthen and shorten during each stroke. This lengthening and shortening of the cylinder assembly is referred to as cylinder stretch, as depicted in Figure 1.3. In fact, the cylinder is very stiff and does not “stretch” or change dimensions.

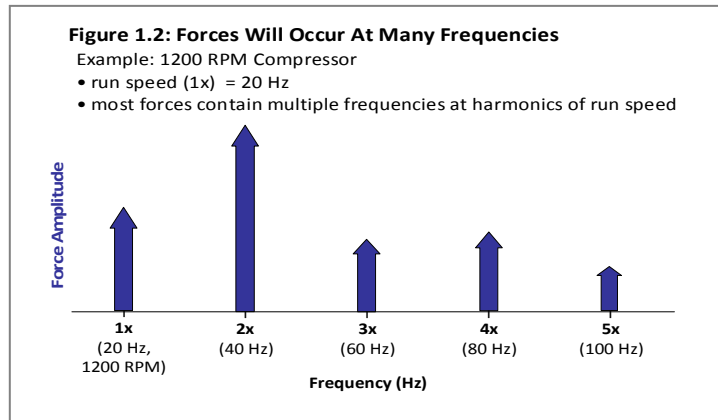

Figure 1.2: Dynamic forces contain harmonic frequencies

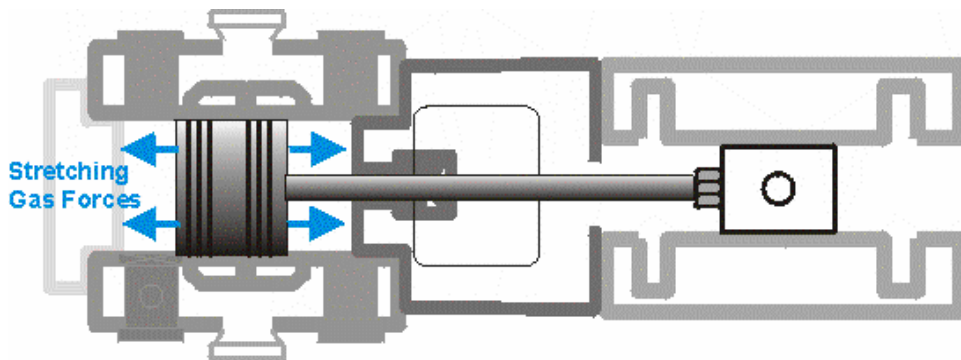

Figure 1.3: Forces on cylinder assembly

Figures 1.4 and 1.5 show cylinder pressure and rod loads for a typical application, in this case a 1000 HP, two throw compressor. As the gas rod loads shown in Figure 1.5 are counteracted by the cylinder, cylinder stretch vibration will result.

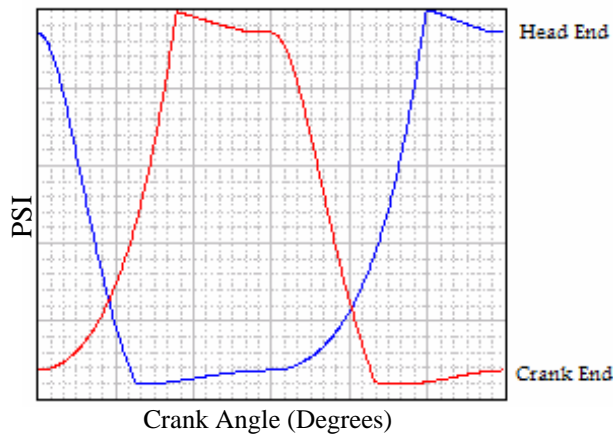

Figure 1.4: Cylinder pressure vs. crank angle

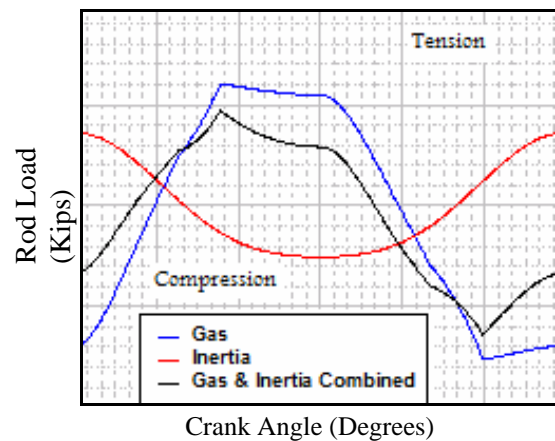

Figure 1.5: Rod load vs. crank angle

A spectrum of the gas rod load forces as taken from the rod load versus crank angle plot is depicted in Figure 1.6. Gas forces occur at every harmonic (order of run speed), however the highest gas forces are typically below 7X or 8X compressor run speed, as is the case in this example. It is interesting to note from Figure 1.6 that the gas forces are much higher than the remaining acoustic (pulsation) induced unbalanced forces (after installing a suitable pulsation control solution).

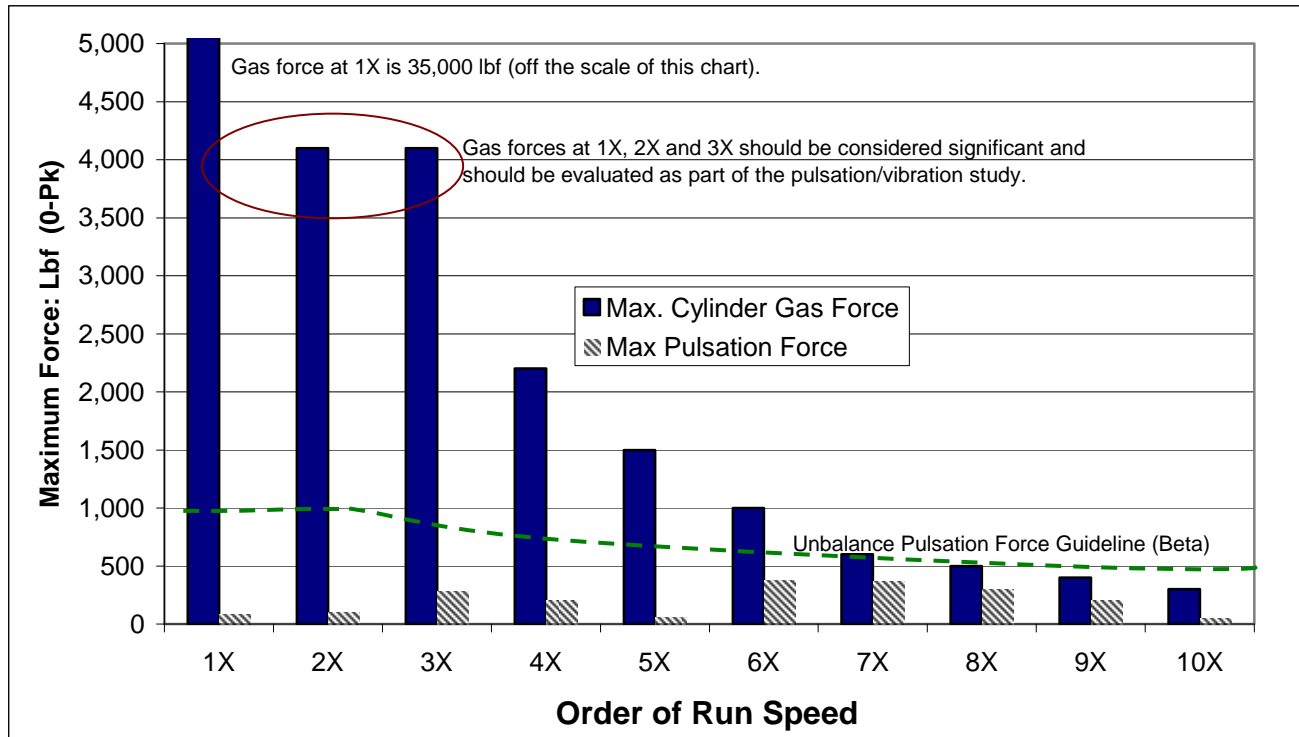

Figure 1.6: Gas forces and remaining pulsation forces (after pulsation control) for a 1000 HP, two throw compressor

Based on Beta's guidelines, the gas forces at 1X, 2X, and 3X as shown in Figure 1.6 are deemed to be significant and evaluated in detail. Gas forces can be directly attributed to failures in piping systems and therefore should be considered. The case study (in section 2) illustrates how relatively low gas forces of 1,700 lbf were the root cause of the vibration problems. The challenge in industry is that the vibration standards (API 618) have not provided guidelines to determine when gas forces will be a problem. This issue is explained in more detail in section 3.

1.3 Mechanical Natural Frequencies

Before we can continue with a detailed discussion of the effect of cylinder gas forces on the compressor package, we have to understand a bit about the dynamic characteristics of the system.

Just like the Hooke's law for a simple spring system, the response of any mechanical system is the product of the dynamic force times the dynamic stiffness. That is:

$$\text{Dynamic Force} \times \text{Dynamic Stiffness} = \text{Response}$$

There are certain frequencies at which the dynamic stiffness of the system is very low. Those are called mechanical natural frequencies (MNFs). The MNF of a pipe, cylinder or bottle assembly is the frequency at which the component naturally wants to vibrate. For example, a spring-mass system oscillates at a constant frequency if the weight is pulled down and then released. Another example, is when a guitar string is plucked it vibrates at its natural frequency to produce the sound we hear. The MNFs of a pipe or piping system depends on the material properties such as density and modulus of elasticity, and geometry such as lengths, schedules, diameters, elbows, supports, etc.

Resonance occurs when a dynamic force acts at the same frequency as the MNF of the system. At resonance, the input vibration can be amplified up to 30 times or more, resulting in significant vibration problems. The goal of the vibration consultant is to avoid resonance even for low amplitude forces.

The MNFs of scrubbers, bottles, cylinders, and attached piping are of most interest when considering cylinder stretch motion from cylinder gas forces. The plots in Figures 1.7 and 1.8 show a few typical modes of interest. Note that these are not plots of vibration or “Operating Deflected Shapes”; these are the shape of vibration of the system that would be observed if the system was impacted and allowed to vibrate or ring on its own.

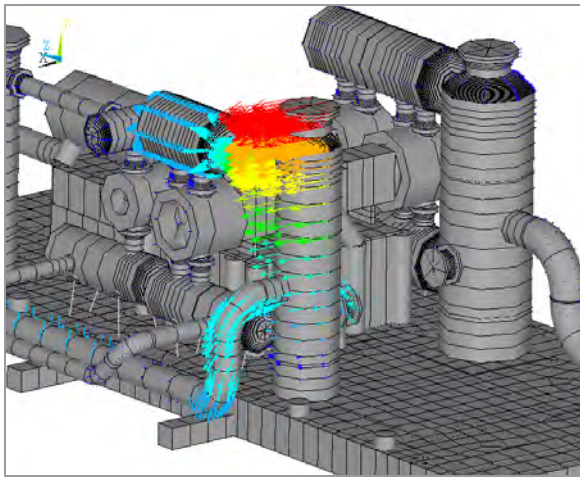

Figure 1.7: Scrubber MNF

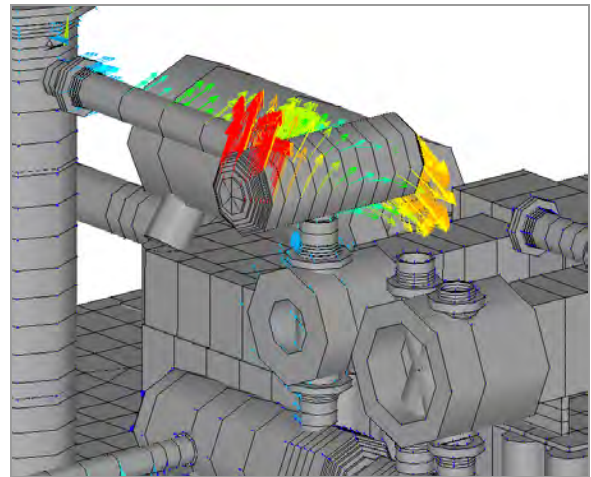

Figure 1.8: Suction bottle MNF

Now, to get back to the discussion of cylinder gas forces; figure 1.9 has two spectra shown. The blue line depicts the various frequency components that make up the alternating gas force acting on the cylinder. For this example, the 1X and 2X run speed components have the highest force amplitudes.

The red line shows the resulting cylinder stretch vibration, that is, the cylinder (displacement) in the horizontal or parallel to piston motion direction. Note that at 9X run speed, cylinder displacement is much higher than at adjacent harmonics, even though the corresponding cylinder gas force is no different. This higher response is because the cylinder is resonant (has its MNF) at 9X run speed in the direction of piston motion.

Cylinder stretch results in vibration of the attached bottles and piping system. This is analogous to the ground motion during an earthquake shaking all the adjacent buildings. The vibration amplitude can be minor, or severe, depending on the cylinder gas force and the MNF of the piping system.

When the magnitude of the source vibration is high enough, or the frequency of the source vibration is equal to the MNF of the attached piping or bottles, excessive vibration and failures can occur.

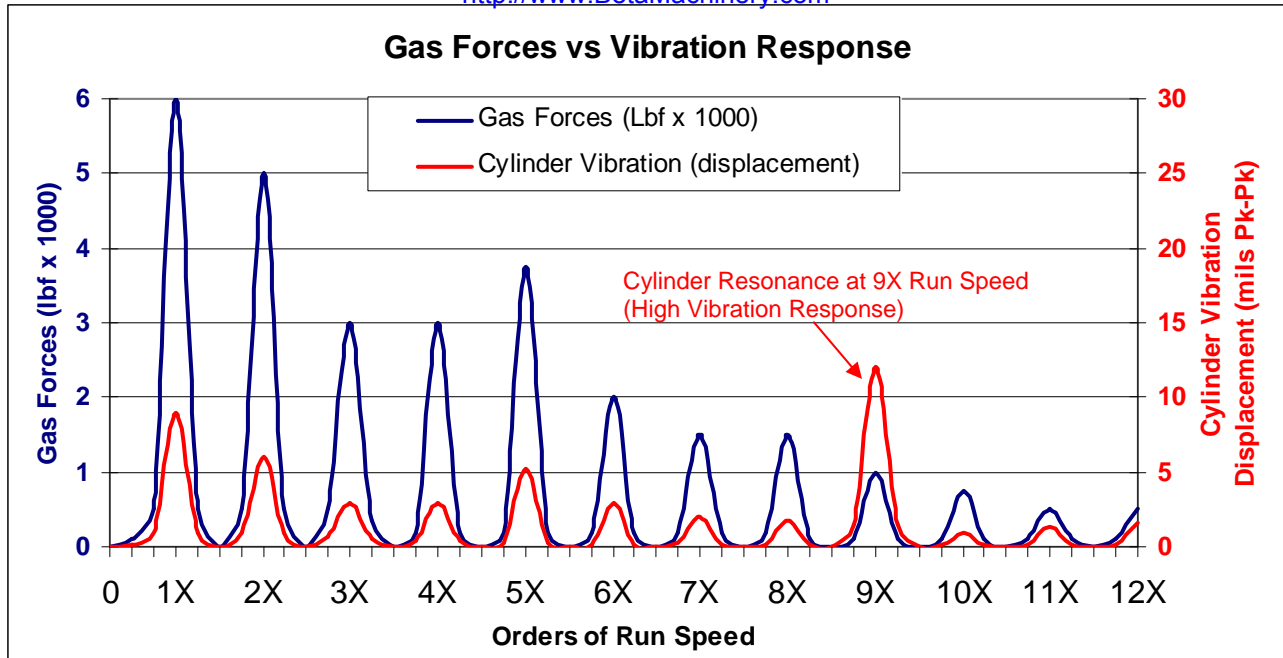

Figure 1.9: Gas force and cylinder vibration displacement vs. frequency in horizontal direction (direction of piston motion)

1.4 Pulsation/Vibration Studies

For new (or modified) compressor packages over 400 HP, it is common to have a pulsation and vibration analysis performed. These studies are based on chapter 7.9 of API 618 5th edition. This section of API 618 outlines the scope, methodology, and guidelines to assess pulsations and the mechanical vibration of the package. API 618 is a global standard applied to slow, medium and high speed machines.

For vibration studies, API 618 has defined two Design Approaches [2]:

Design Approach 2 (DA2), involves designing pulsation control systems, such as bottles and orifice plates to limit the dynamic forces caused by pulsations. The assumption for DA2 is that by limiting the pulsation forces, the vibrations will be acceptable. A DA2 study is limited to pulsation analysis, and does not include the analysis of mechanical resonance, or the evaluation of gas forces. Note: limiting the pulsation forces in the bottles and piping does not reduce the gas forces acting on the cylinders. Remember, the gas forces can be quite large.

Design Approach 3 (DA3), includes both pulsation analysis and mechanical analysis of the compressor system. This involves calculating the MNFs of the compressor system and modifying the system to avoid resonance (step 3a). This step requires utilization of Finite Element Analysis (FEA) to calculate the MNFs and the free vibration mode shapes of piping, pulsation bottles, scrubbers, cylinders, etc. In some cases, further analysis is required (step 3b). For step 3b, the system forces are applied to the model and the resulting vibration and stresses are calculated. Guidelines, for when the DA3 should include step 3b, will be given later.

1.5 Separation Margin to Avoid Resonance

The goal of a basic mechanical analysis (DA3, per API 618) is to avoid resonance. This occurs when MNFs are at the same frequency as significant dynamic forces. The difference in frequency between the MNF and a dynamic force is called the separation margin. The separation margins for a typical MNF are shown in Figure 1.10.

API 618 5th edition provides two separation margins to consider for mechanical analysis per paragraph 7.9.4.2.5.3.2 [3]:

a) *“The minimum MNF of any compressor or piping system element shall be designed to be greater than 2.4 times the maximum rated speed.”* This requirement is to prevent MNFs from being resonant with 1X or 2X compressor run speed. The largest dynamic loads are generated at 1X and 2X compressor run speed including frame dynamic forces and moments, rotating unbalance, pulsation forces, and cylinder gas loads causing cylinder stretch. Generally, this requirement is met for most compressor components. For faster compressor application, such as those that are rated for 1800 RPM, this requirement can be difficult to achieve.

b) *“The predicted MNFs shall be designed to be separated from significant excitation frequencies by at least 20%.”* This requirement addresses the dynamic loads at harmonics higher than 2X compressor run speed. These loads include pulsation forces that are above the API 618 guideline levels, as well as the higher harmonic cylinder gas loads that cause cylinder stretch.

API 618 5th edition specifies that if the separation margins are not met, then forced response mechanical analysis is required per Appendix M, steps 3b1 and 3b2. The forced response analysis will calculate the vibration levels and resulting dynamic stress, to ultimately determine if changes to the design are necessary.

Example: Separation Margins on 1000 RPM Compressor

Figure 1.11 illustrates the required separation margins for a fixed speed compressor operating at 1000 RPM (16.67 Hz at 1X run speed):

- a. All MNFs should be above 2.4X run speed. In this case, above 40 Hz.
- b. The 20% separation margin also applies to other harmonics (since dynamic forces occur at each harmonic). For example, look at 3X run speed. The MNF should not occur between 40 Hz and 60 Hz.

If, for example, there were high gas rod loads at 3X compressor run speed, bottles and piping would have to be modified to have MNFs increased above 60 Hz. Adding supports, changing the piping system, and other modifications would be costly to the packager (and owner). In this case, let's assume we increase the MNF to 62 Hz. We have now created a potential resonance problem at 4X.

This example illustrates that the 20% separation margin will be very *difficult, or even impossible, to achieve at harmonics above 2X compressor run speed*. At 3X run speed or higher, the required separation margins overlap. This means there is no place along this frequency spectrum to place bottle or piping MNFs so they will avoid resonance. Cylinder gas forces will occur at every order of run speed, and can be quite large.

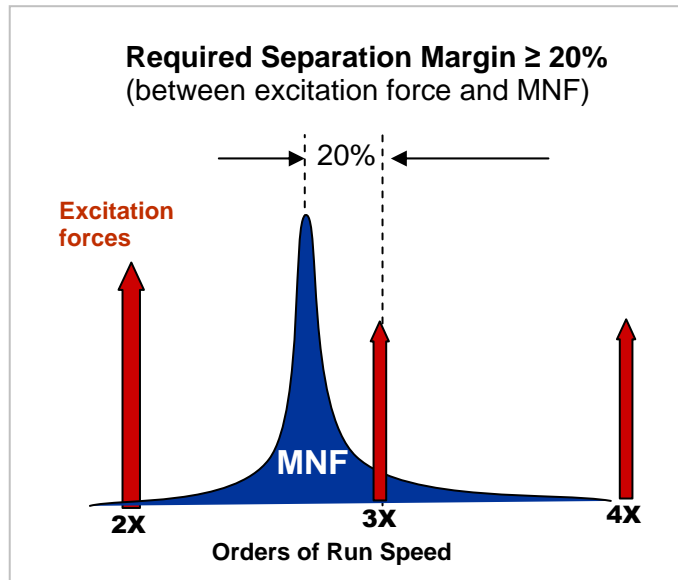

Figure 1.10: Required Separation Margin (per API 618)

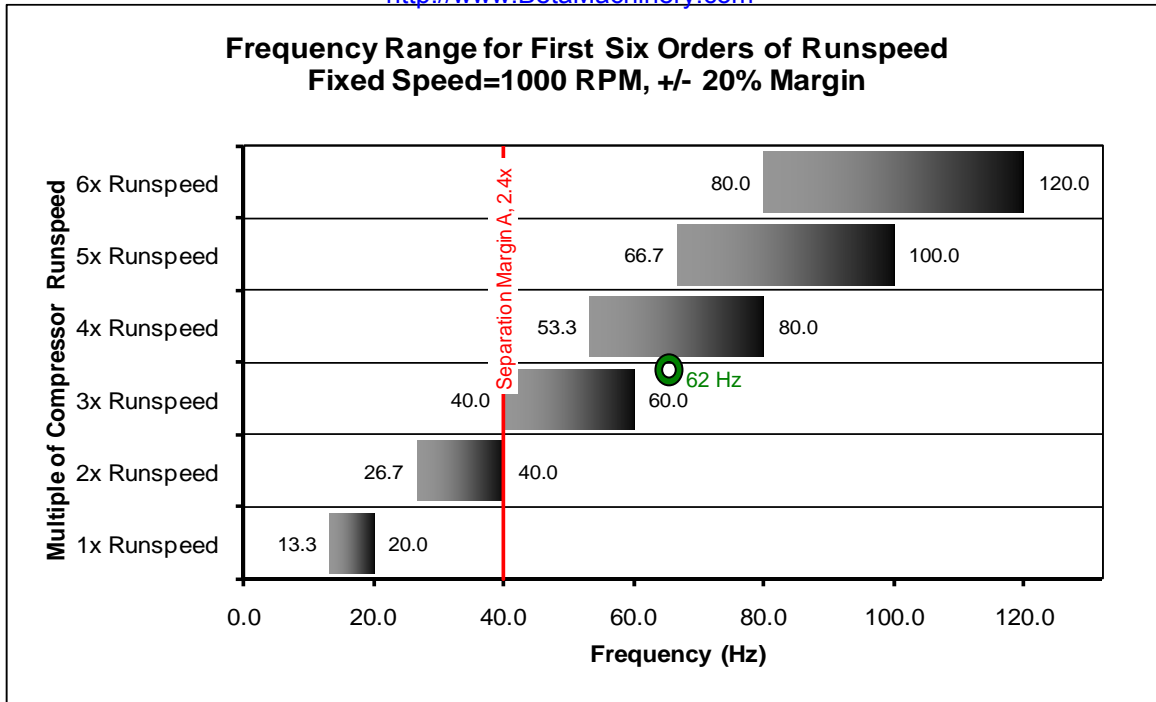

Figure 1.11: Frequency range to avoid for 1000 RPM (+/-20% separation margin)

Section 2 is a case study that illustrates how gas forces result in vibration problems. This is a common issue for compressor applications. Section 3 provides recommendations for evaluating gas loads and mechanical analysis.

2.0 Case Study – Field Example of Cylinder Gas Loads Causing Problems

The following case study is of a variable speed compressor package in a gas gathering type application where cylinder gas forces did cause problems. Some specifics on this unit are given below.

- Sweet natural gas, 0.59 SG
- Three stage
- Four Throws
- 750 -1200 rpm
- 1680 HP driver (Waukesha L7044GSI Engine)
- Ps=63 psig
- Pd=1400 psig
- Cylinder loading – head end variable volume pockets first and second stages

The unit originally had a DA3 study done many years ago, but with limited operating conditions. The analysis only considered the 2.4X run speed MNF guideline. The fact that cylinder gas forces could be significant at other harmonics beyond 2.4X was not considered.

Anadarko had a failure of the third stage suction bottle on a recently installed unit. A field check quickly revealed that a missing clamp under the grating resulted in the bottle and the suction line being resonant at 2X run speed. That clearly did not meet the API 618, 5th edition 2.4X natural frequency guideline. But, that is not the real point of this story.

With the clamp installed, the suction line and bottle were still resonant, but at 3X run speed rather than 2X. The mode shapes were remarkably similar. The 3X mode is shown in Figure 2.1. The vibration of the free-standing elbow, shown in Figure 2.1, was as high as 3 ips pk at 50 Hz in the direction of piston motion. This vibration is clearly above the 1 ips pk guideline. Six other units of the same design were checked and the vibration of the elbow in those units varied from 0.8 ips pk to 2.5 ips pk in the 48 – 50 Hz

range. Those units had operated over the complete speed range, for varying amounts of time, but none had a failure related to the vibration.

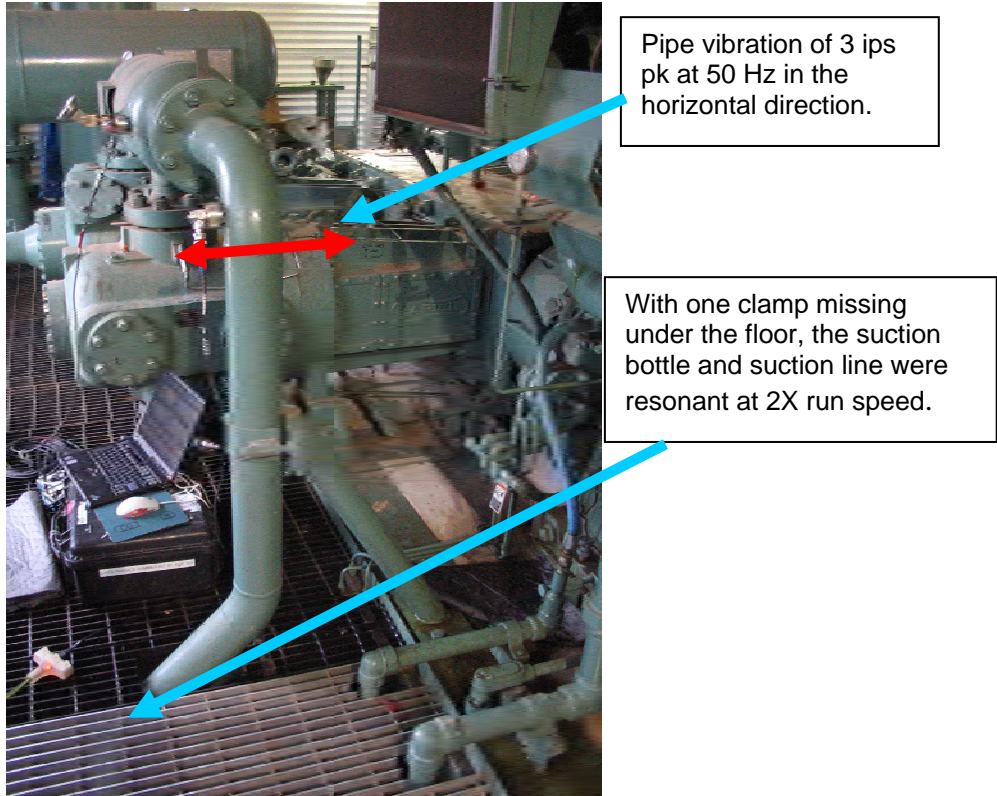

Figure 2.1: Third stage suction bottle and pipe with a vibration issue

Variations in the pipe support locations and, or, pipe strain were suspected to be responsible for the widely varying response between units. Pipe strain was checked and corrected on one unit, but it did not change the vibration significantly. Even more puzzling, the first unit with the highest vibration was checked again later the same day and the peak vibration on the elbow was 0.8 ips pk at 3X, versus 3 ips pk that morning.

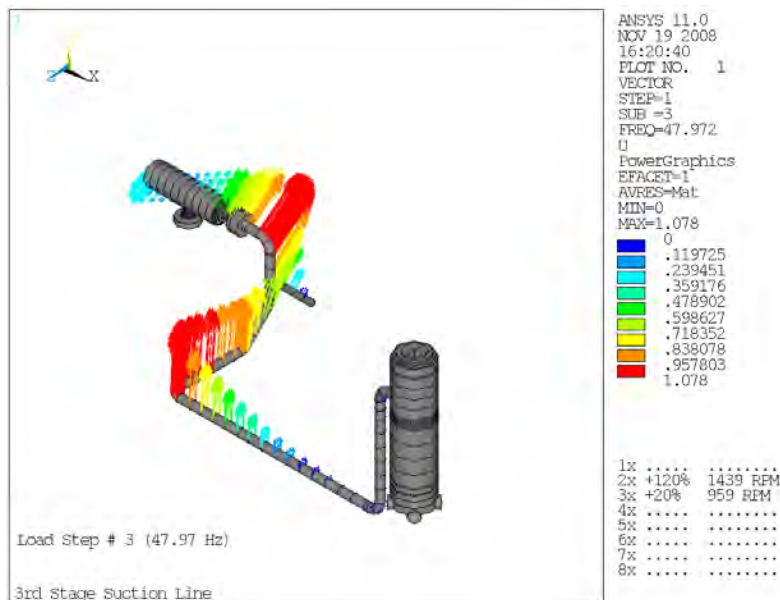

Figure 2.2: 3X MNF (resonant when the unit runs at 959 rpm)

So, what changed during the day? No one else had been at that compressor site, so the pipe support tightness should have been unchanged. As well, there were no changes in pockets on any stage. The compressor inlet suction pressure varied considerably during the day resulting in the interstage pressures also changing. The 3rd stage suction pressure had been 585 psi in the morning when the vibration was a problem. In the evening, it was 495 psi and the vibration was acceptable. Was that the clue?

The pressure pulsations and shaking forces from pulsations were calculated for the third stage suction system for the full range of operating conditions and speeds. The shaking forces did not change significantly at 3X run speed, so this was not the cause of the high vibration.

The cylinder gas forces were calculated over the compressor inlet suction pressure range and the answer became clear. The cylinder gas forces at 3X run speed on the third stage of the compressor had increased by 100%. See Table 2.1.

Table 2.1: Variation of Third Stage Cylinder Gas Forces With Third Stage Suction Pressure

Suction Pressure (psig)	Gas Forces in Cylinder (lbs peak)			
	1x	2x	3x = 50 Hz	4x
final 495	28,000	2,300	800	200
525	27,500	2,300	1,100	200
555	27,000	2,200	1,400	200
initial 585	26,500	2,200	1,700	200

There was concern that the excessive vibration of 3 ips pk could result in fatigue failure. Detailed calculations of the stresses in the suction bottle were done and the stresses at 3 ips pk were found to be acceptable. See Figure 2.3.

The design of the third stage bottle was changed for future copies of the package. Instead of the bottle being perpendicular to the cylinder, it was oriented parallel to the cylinder. The new bottle and suction piping layout was modeled and was found to be acceptable from the acoustical and mechanical viewpoints.

Case study summary:

- This example illustrates how gas forces can be significant.
- Operating conditions changed in the unit, resulting in significantly different excitation forces.
- Excessive vibration resulted when the cylinder gas force was resonant with the piping MNF.
- The initial pulsation and vibration study did not include all current and future operating conditions.
- Cylinder gas forces should be included as part of a mechanical analysis.

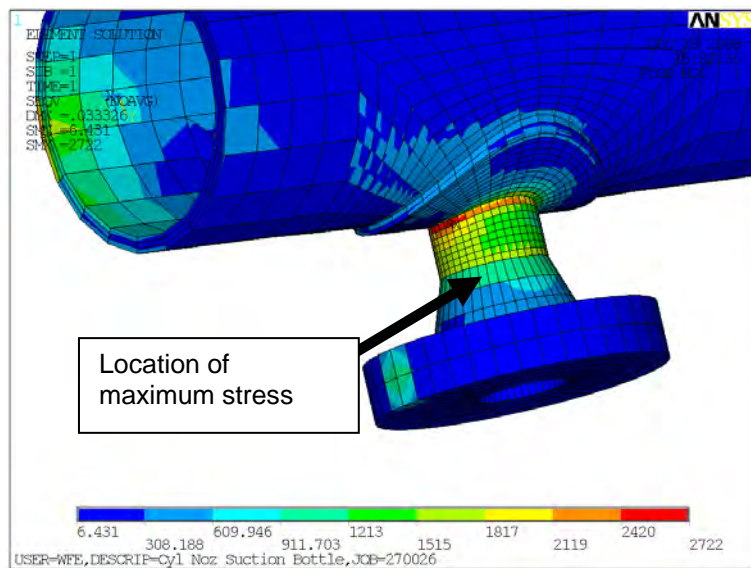

Figure 2.3: Evaluate stress in the suction bottle due to measured vibration

3.0 Evaluating Cylinder Gas Loads

3.1 Does an API 618 5th Edition (Design Approach 3) vibration study avoid problems with cylinder gas forces?

Not necessarily. There are two problems with the following definition of separation margin as described in API 618, “The predicted MNFs shall be designed to be separated from significant excitation frequencies by at least 20%.”[3]

- a. *There is no definition for when cylinder gas forces are “significant” and must be evaluated.* While there is a clearly defined guideline for pulsation forces, there is no reference or guideline for gas loads. Therefore, higher frequency cylinder gas loads are often neglected and high vibrations and fatigue failures of components can result.
- b. *It is impossible to achieve a 20% separation margin for higher order gas forces.* The example in section 1.5 illustrates that the required separation margins overlap for orders at, or above, 3X run speed. This means that a forced response analysis is required to assess vibration and stress amplitudes. This extra analysis can be expensive and technically more demanding. The extra analysis is often not included in the initial quote. As a result, detailed vibration/stress results including gas forces are often not provided. This creates confusion for packagers and owners.

Improvements to the API 618 Standard include more clarity to appropriately analyze the mechanical system to include gas forces.

Given these limitations in the Standard, the authors provide the following recommendations for consultants, packagers, and owners.

3.2 When Gas Forces Should be Evaluated in a DA3 Study

There are two methods to evaluate the vibration risk due to excessive gas forces. One can be done for bidding purposes. The other is more accurate, but is done by the vibration consultant.

3.2.1 Simple Check for Purposes of Bid Document

It is recommended that packagers, engineering consultants, or owners, evaluate their application during the design stage with respect to the risk of vibration due to cylinder gas forces. The following rule of thumb can be used:

- **Compressor frame: over 700 HP/Cylinder, or**
- **If the compressor will exceed 80% rated rod loads** (for compressors over 300 HP per throw).

If the above condition exists, then the specification for a vibration study should specifically include the following:

- Forced response analysis of the compressor piping (Step 3b1 per API 618, 5th edition). See section 3.3 below for more information.
- Vibration report to document all gas loads (for all harmonics up to 20X run speed), and for each operating condition.
- Document the predicted vibration and stress amplitudes compared to guideline.

Unless specified, there is no guarantee that a pulsation and vibration study will evaluate cylinder gas forces. The lack of a specific definition for when cylinder gas forces are significant results in these forces often being neglected and, thus, an increased risk to failure of the compressor package.

3.2.2 Analysis of Gas Load Harmonics – A More Accurate Assessment

Based on the authors’ experience, a simple and more robust method is available to determine when gas forces pose a vibration risk. This test can be run prior to starting the mechanical analysis. It may highlight situations where a forced response analysis can be avoided (or, to help justify that one is necessary).

Ask your vibration consultant to do this simple calculation as part of a standard pulsation study:

- Calculate the cylinder gas loads for each operating condition, and for each harmonic (up to 20X).

- Forced response analysis is required when cylinder gas loads at higher harmonics (typically 3X to 8X) are greater than 10% of the rated rod load for the compressor. Special consideration is also required for in-phase modes of bottles that are common to multiple cylinders.

3.3 Calculate Vibration and Stress Amplitudes Due to Gas Forces (Forced Response Analysis)

As previously demonstrated, even for fixed speed applications the separation margins may be impossible to meet for higher frequency cylinder gas loads. Also, it may not be necessary to change the design, since vibration of bottles and piping may be acceptable, even if some modes are resonant with higher frequency cylinder gas loads.

The only way to then determine if a design is acceptable is to complete a forced response analysis. Forced response analysis, also known as harmonic analysis, is the application for the excitation forces to the finite element (FE) model. *The results of the analysis are the actual steady state vibration levels that could be expected, along with the resulting dynamic stress.* The goal of the analysis is to achieve dynamic stress in the bottles and piping that is below the fatigue endurance limit for the material.

Example: Forced Response Analysis Procedure

Figure 3.1 illustrates the FE model of the suction bottle and associated system. This model is used to calculate the suction bottle MNF, which in this case is 61.5 Hz. The red indicates the largest amplitude of motion for that mode. As can be seen, this is a cantilever mode of the suction bottle in the direction of piston motion. Gas loads are then applied to the model (as shown in Figure 3.2).

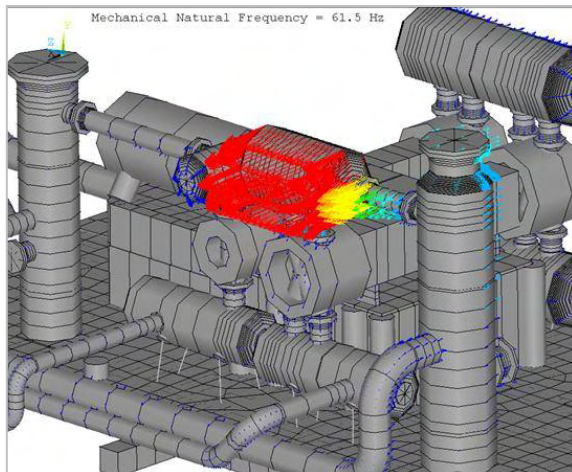

Figure 3.1: Finite Element Analysis used to calculate the MNF of suction system

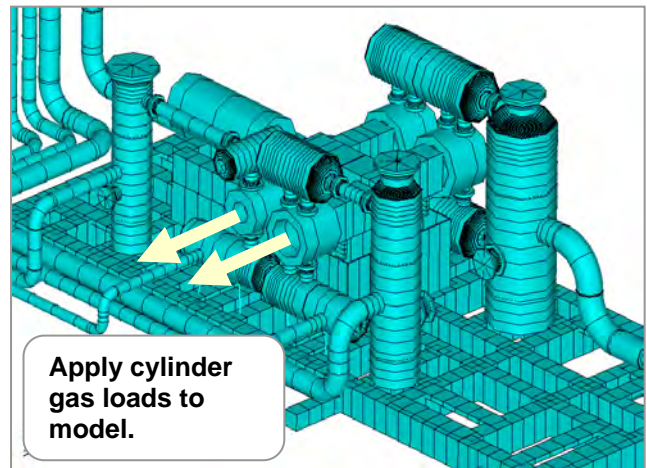

Figure 3.2: Cylinder gas forces applied to FE model (forced response analysis to determine vibration and stress magnitudes)

The results of the forced response analysis are shown in Figures 3.3 and 3.4. The maximum vibration amplitude of the suction bottle is plotted versus frequency in Figure 3.3. Note that the amplitude is greatest at the MNF, 61.5 Hz. The dynamic stress corresponding to the worst-case vibration is plotted in Figure 3.4, where red indicates the areas of highest stress.

To predict vibration and dynamic stress accurately and to determine if a design is acceptable, a detailed FE model is required. ANSYS or equivalent FEA software modeling tools are necessary to correctly model the vessels and internals. More basic FEA software programs may have limitations making them unacceptable for forced response analysis.

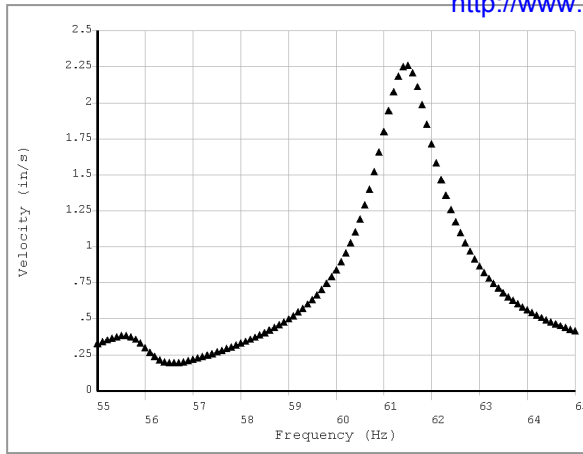

Figure 3.3: Predicted vibration due to cylinder gas forces

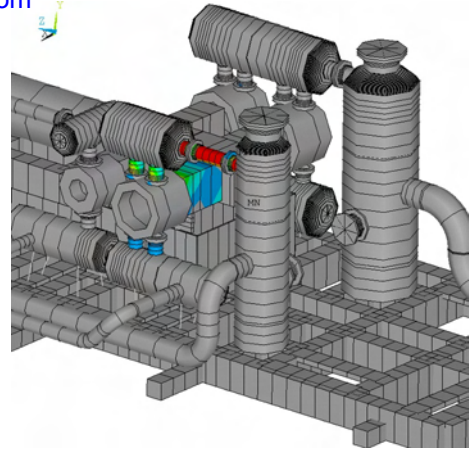

Figure 3.4: Dynamic stress in bottle and piping due to cylinder stretch excitation at bottle MNF. (Red indicates location of highest stress)

Conclusion and Recommendations

Cylinder gas loads and the resulting cylinder stretch are significant, especially for high power applications. Numerous field problems, including the example in this paper, illustrate the vibration problems associated with gas forces. Since API 618 does not specifically address cylinder gas forces for pulsation and vibration studies, the authors recommend that the Standard be modified.

Firstly, a guideline should be adopted to identify when gas forces are to be considered “significant”. The authors recommend applying the following rule of thumb during the bidding process:

A forced response analysis to assess vibration and stress amplitudes (Step 3b1, API 618 5th edition) will be required when:

- 1) the power per compressor throw is over 700 HP, or
- 2) the overall rod loads exceed 80% of allowable (for compressors over 300 HP per throw).

For a more accurate assessment of the cylinder gas loads, the amplitude of the gas loads at individual harmonics should be reviewed. When the cylinder gas loads at harmonics above 2X are greater than 10% of overall rated rod load, it is recommended that the vibration and stress amplitudes be calculated using a forced response study. For in-phase bottle MNFs at higher frequencies, more conservative guidelines are required.

Secondly, API 618 should offer further clarification on the methodology to employ for higher order forces since the 20% separation margin is not achievable. Specifically, forced response analysis including the cylinder gas forces should be required when the separation margins are not possible and the forces are significant.

Owners should also be involved in the specification of vibration studies to ensure the appropriate analyses are defined in the bid documents. For new (or modified) units, the above rule of thumb can be applied during the bidding process to determine if forced response analysis is likely going to be required. Once a project is in progress, the owner should ask the pulsation consultant to publish the gas rod loads for all conditions, for all harmonics. When gas loads at harmonics above 2X are greater than 10% of rated rod load, a forced response analysis can be requested.

For existing units with vibration problems, check to determine if the vibration is related to cylinder gas forces. To assess this possibility, obtain spectral vibration data in the horizontal direction (direction of compressor piston motion). An impact (bump) test is also required to measure the system MNFs and identify resonance problems. Testing the unit for a range of compression ratios or cylinder loading will also provide information to diagnose vibration caused by cylinder gas forces.

References

[1] 1991, "Cylinder Stretch as a Source of Vibration in Reciprocating Compressors," Brian Howes, Kelly Eberle and Val Zacharias, www.BetaMachinery.com

[2] 2008, "New API Standard 618 (5th Ed.) and Its Impact on Reciprocating Compressor Package Design," Shelley Greenfield and Kelly Eberle, CompressorTech^{Two}.

[3] API Standard 618, 5th Edition, "Reciprocating Compressors for Petroleum, Chemical, and Gas Industry Services," Dec 2007